

Application

Compatible with Variable Air Volume ("VAV"), Constant Air Volume ("CAV") and Variable Volume Temperature ("VVT") equipment. Applications include fan powered boxes and boxes with local reheat, cooling or humidity control.

Network

Q1 is built to operate on LonWorks FT-10 channels connected with twisted-pair wire. Network update throttling is incorporated and can be adjusted via the plug-in. Very large networks of devices can be built using IP backbones and routers available from many vendors. Neuron 5000, no cost LNS commissioning, no credits required.

Software

LNS Plug-in provides graphical user interface for configuration and monitoring. Plug-in simplifies hardware I/O customization, communication parameters, control sequences. Plug-in is to be executed from-within network management tool such as LonMaker for Window or similar, or stand-alone when management application is not available

Software features include:

- Changeable network variable types
- 5 PID loops
- Input , output properties and network update throttling
- Slave mode for any unused I/O, which can be bound to another controller

Hardware

- 12 inputs include: 2 resistive-sensor-only inputs and up to 10 universal inputs. Universal inputs can accept 0-10V, 0-20mA, resistive and dry-contact signals. UI type is adjustable by plug-in, no jumpers.
- 8 Digital outputs are triac digital on/off or floating point.
- 4 Universal analog outputs are capable of 0-10 volts and adjustable within that range, or digital (0-12V DC)
- 16V DC on-board power supply provides power for loop-powered 4-20mA sensors.
- Analog outputs are fused.
- RJ11 jack provides quick access to network and 16V DC power for handheld.
- DIN rail mounting is integrated into enclosure for rapid installation.



Q1 is based on the Neuron FT-5000 microprocessor and designed to control variety of HVAC applications. It features rich network interface with up to 250 variables. All controller features are adjustable by LNS Plug-in or a hand-held device. Q1 devices can operate stand-alone or as a networked solution. In a networked environment Q1 can share information with other controllers peer to peer on a flat line of communication. Networks of thousands of devices can easily be created. When monitored by InetSupervisor software, web-based control and monitoring is enabled, large trend, schedule, and alarm storage is available. Q1 hardware can optionally be expanded with a variety of feature add-on boards that enhance the Q1 with features like differential pressure sensing, etc.

LonWorks guidelines are strictly observed and Q1 is interoperable with other like controllers for best network integration experience and promotes the use of industries best products in a network. The Q1 hardware is build to high quality standards and is backed by two-year warranty. All hardware is build in the USA using eco-friendly, lead-free technology and is **RoHS** compliant.

Features:

- Industry leading flow sensor with 20bit resolution; Floating point or propotional external damper actuator control. Four air flow setpoints; Up to four stages of fan. Discharge temperature control, External occupancy input, Cooling / Heating up to 4 stages digital , analog or mixed; IAQ control; Humidity control; Network traffic management; Fully decoupled I/Os from sequence can be used for control of external equipment with a PID loop; Optimum start.

Q1-VAV-2.x.x.x

Hardware Specifications

Made in USA RoHS  

Environmental	
Operating temperature:	0°-70°C (32°-158°F)
Operating humidity:	0-90% non-condensing
Storage temperature:	-20°- 70°C (-4° - 158°F)
Power	
Typical power consumption:	5-6VA plus peripherals.
Max power consumption:	30VA including peripherals.
Supply voltage:	20-30V AC Class II or 22-50V DC
Fuse:	Fuse: 1.8A resettable fuse
Enclosure	
Installation:	Mounts on 35mm Din-Rail.
Color:	Off-white
Material:	ABS
Connectors:	Connectors: Green, pluggable, 10 position.
Hardware	
Processor:	FT-5000, 8bits, 80MHz
Memory:	48k application memory
Transceiver:	FTT-10; 78kbps free topology, polarity free
Indicator light:	Multicolor LED, power, status, service
Comm jack:	RJ11; power, LON, hand-held comm.

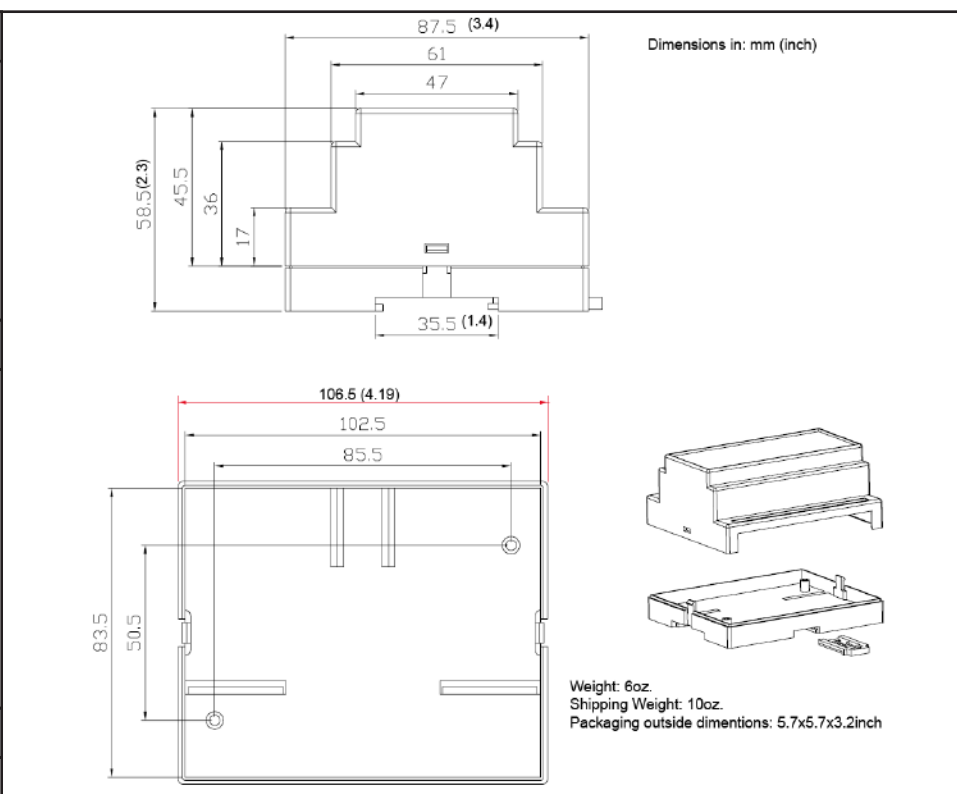

Inputs:
 Q1 hardware platform always has 2 resistive sensor inputs. In addition there are up to 10 Universal Inputs. Number of UIs depends on the part number. Input resolution is 12 bits. UIs are software configurable.

- Voltage 0-10VDC
- Current 0-20mA
- Digital Dry contact
- Resistive sensors
 - Thermistor 10kΩ Type 2 (recommended), Type 3
 - Thermistor custom translation table on each UI
 - Potentiometer with custom translation table on each UI

Outputs:
 Q1 hardware has up to 8 triac digital outputs and 4 analog outputs. Number of outputs depends on the part number. Triac outputs can source 24AC or route external AC power depending on power jumper (P6) setting.

- Digital Triac
 - Triacs rated for 1A at 24VAC for a total of 2A all outputs.
 - External power supply or
 - Sourcing of 24VAC. See jumper setting.
- Analog Universal
 - 0-10VDC adjustable, linear
 - 0 or 12VDC digital
 - 35mA max at 30°C.
 - Resolution 8 bit
 - Auto reset fuse at 125mA

LED color codes:
 Red/Green alternating = Powered on and application less
 Green = Powered on and configured
 Red = Powered on and Neuron chip fault
 OFF, no color = No power

Q1-VAV-2.x.x.x

Made in USA RoHS



FCU 8010 profile

All variables with SNVT_xxx have Changeable Types feature.

FCU 8010 functional block information.

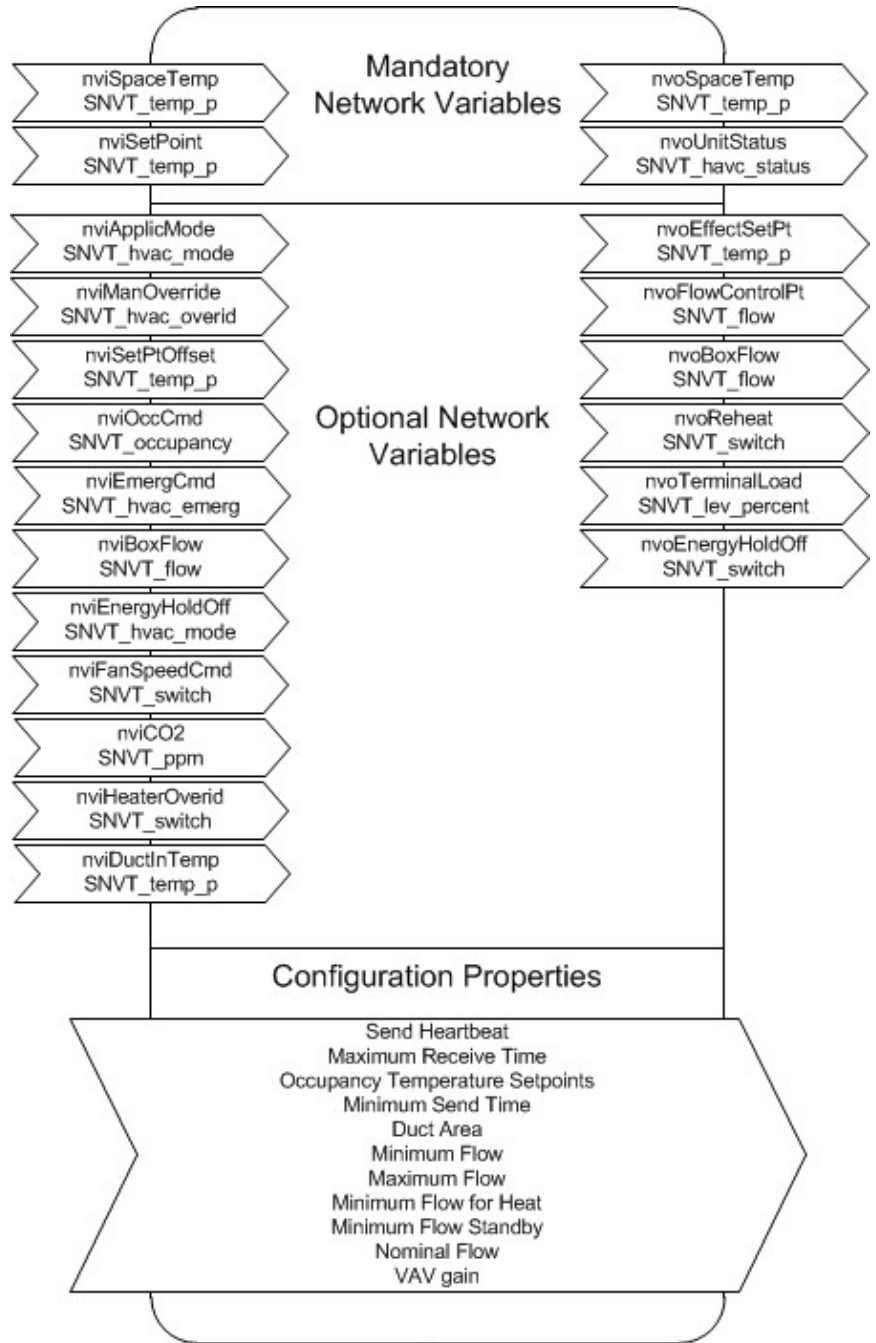

Continue on next page

Q1-VAV-2.x.x.x

Made in USA RoHS



GSA Advantage!

FCU 8010 profile

Continued from previous page

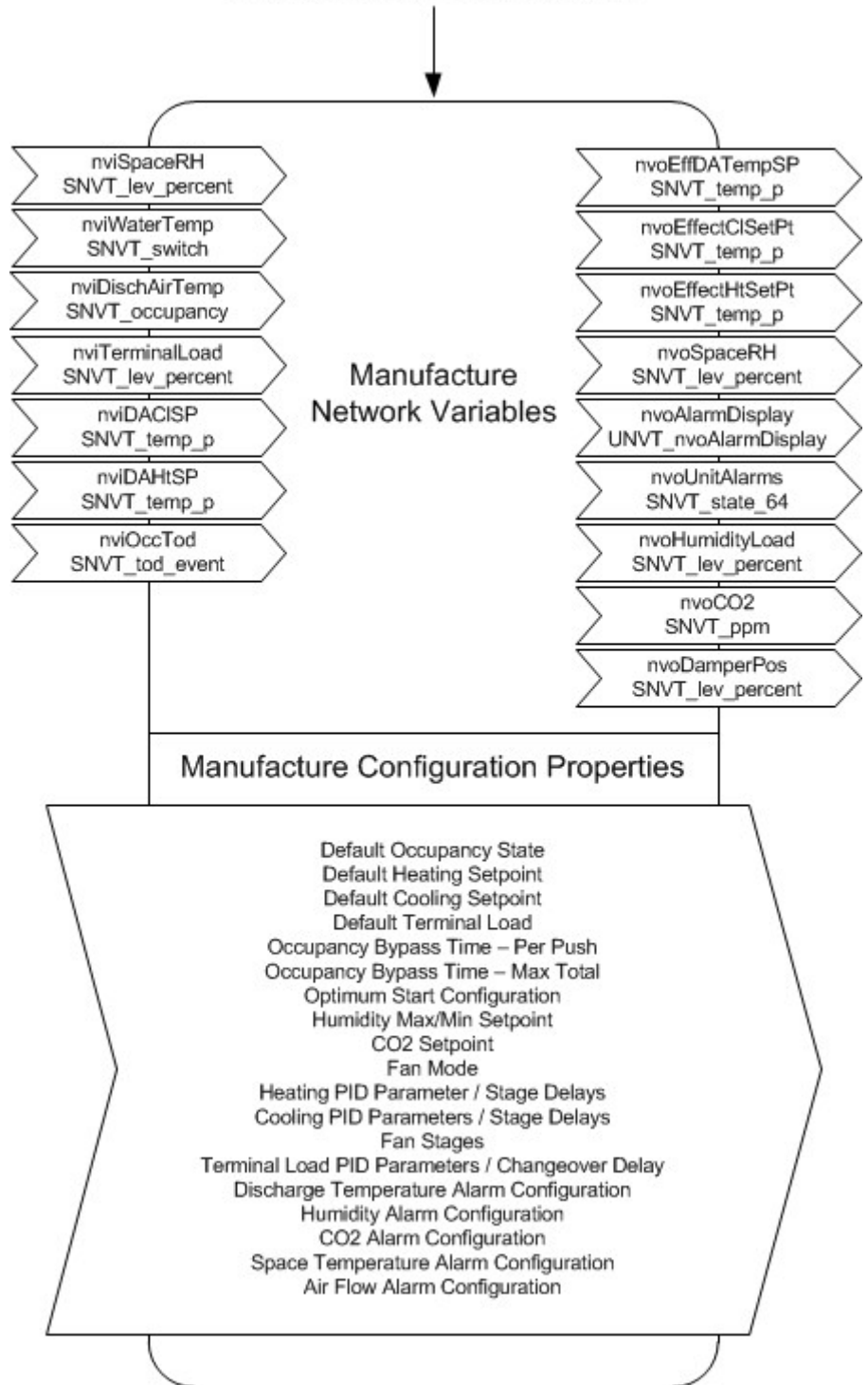

Q1-VAV-2.x.x.x

Made in USA RoHS



Open Loop Sensor profile

Open Loop Sensor profile is used by all physical inputs. Inputs can be used as slave I/O or as part of the main application.

All variables with SNVT_xxx have Changeable Types feature.

Open Loop Sensor functional block information.

(Physical inputs)

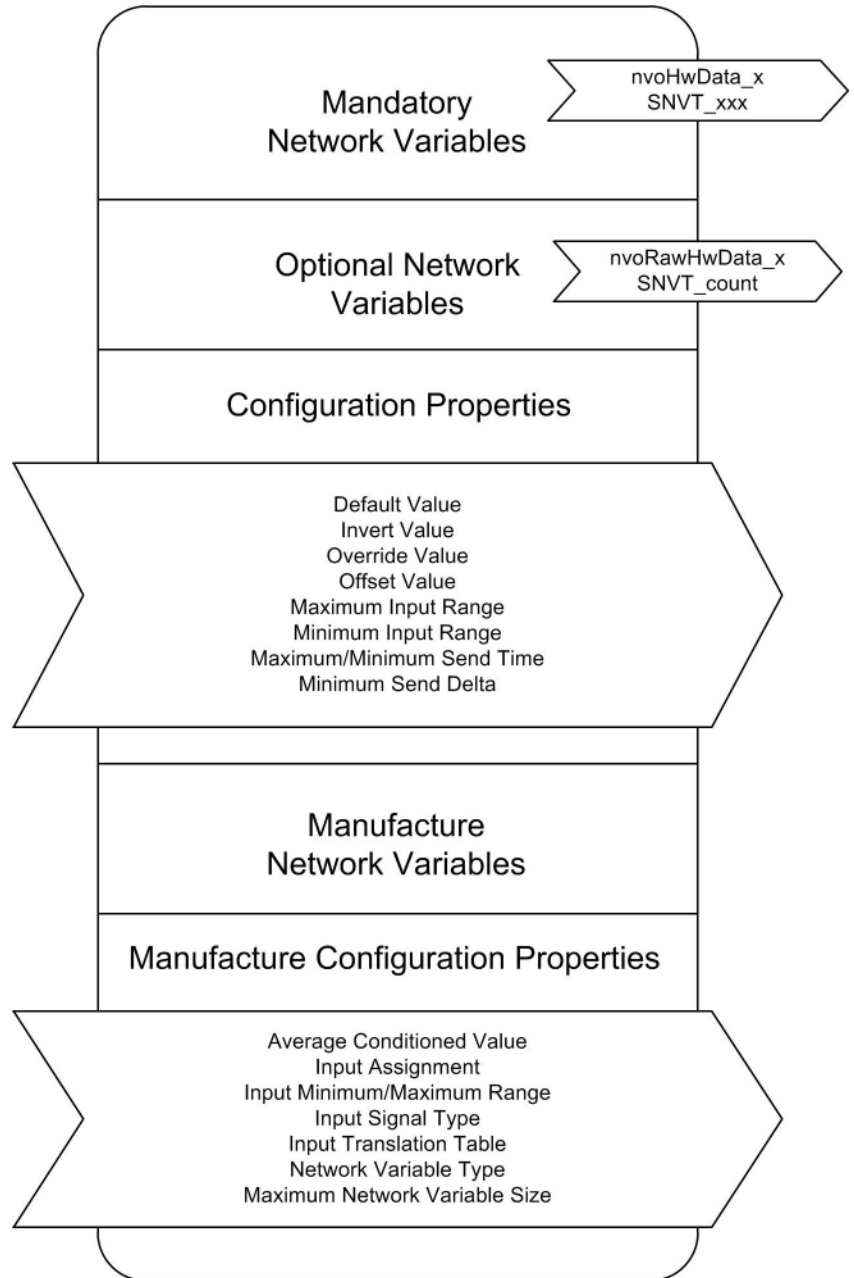

Q1-VAV-2.x.x.x

Made in USA RoHS



Open Loop Actuator profile

Analog Output profile is used by all analog outputs. Outputs can be used as slave I/O or as part of the main application.

All variables with SNVT_xxx have Changeable Types feature.

Analog Outputs functional block information.

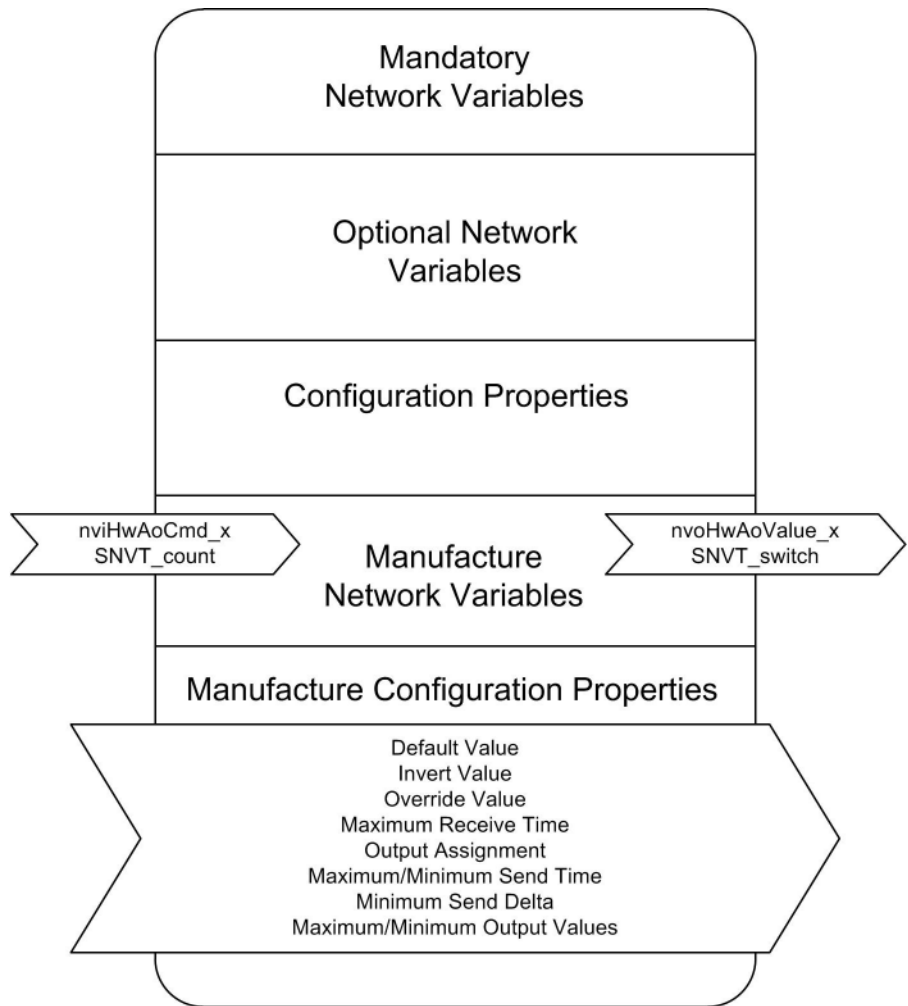

Q1-VAV-2.x.x.x

Made in USA RoHS



Open Loop Sensor profile

Digital Output profile is used by all digital outputs. Outputs can be used as slave I/O or as part of the main application.

All variables with SNVT_xxx have Changeable Types feature.

Digital Outputs functional block information.

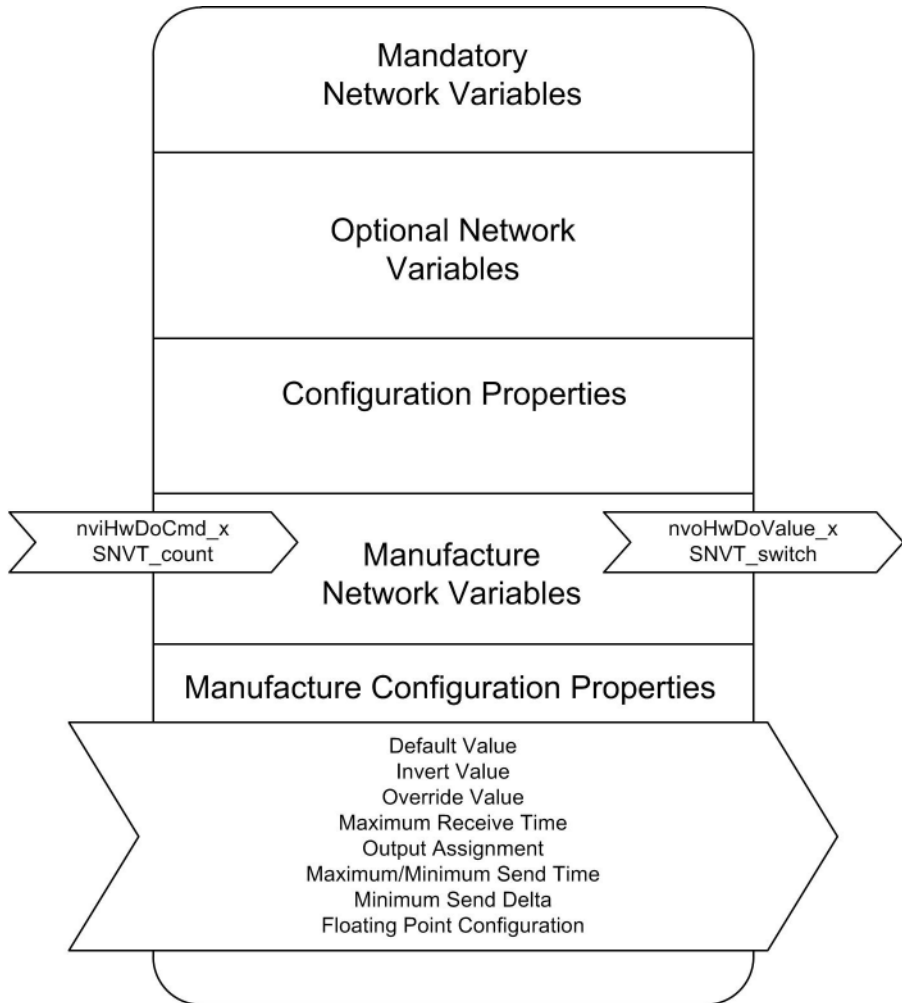

Q1-VAV-2.x.x.x

Made in USA RoHS



Node Object profile

Node Object profile includes hardware specific network variables. The variables are for internal and use by the plugin only.

Node Object functional block information.

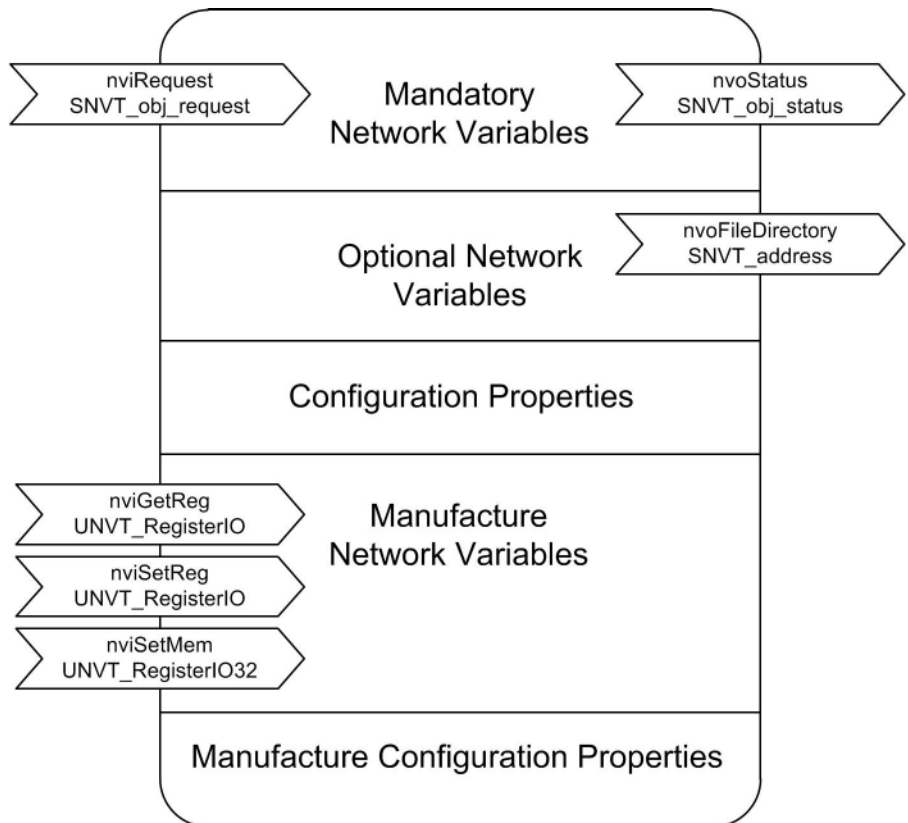

Part Numbers

Q1-AAA-2.x.x.x

Q1 indicates hardware platform and is always present.

AAA- Application name

- EXP
- FCU
- HPU
- NetStat
- PID
- RTU
- VAV

2.x.x.x - I/O configuration

- 2.0.2.0 = 2-IN, 0-UI, 2-Triac, 0-AO
- 2.2.4.0 = 2-IN, 2-UI, 4-Triac, 0-AO
- 2.4.5.2 = 2-IN, 4-UI, 5-Triac, 2-AO
- 2.8.6.4 = 2-IN, 8-UI, 6-Triac, 4-AO
- 2.10.8.4 = 2-IN, 10-UI, 8-Triac, 4-AO